

INTEGRA

Automation – Inside the gate !

Installation Kit for Swing Gate (Iron)

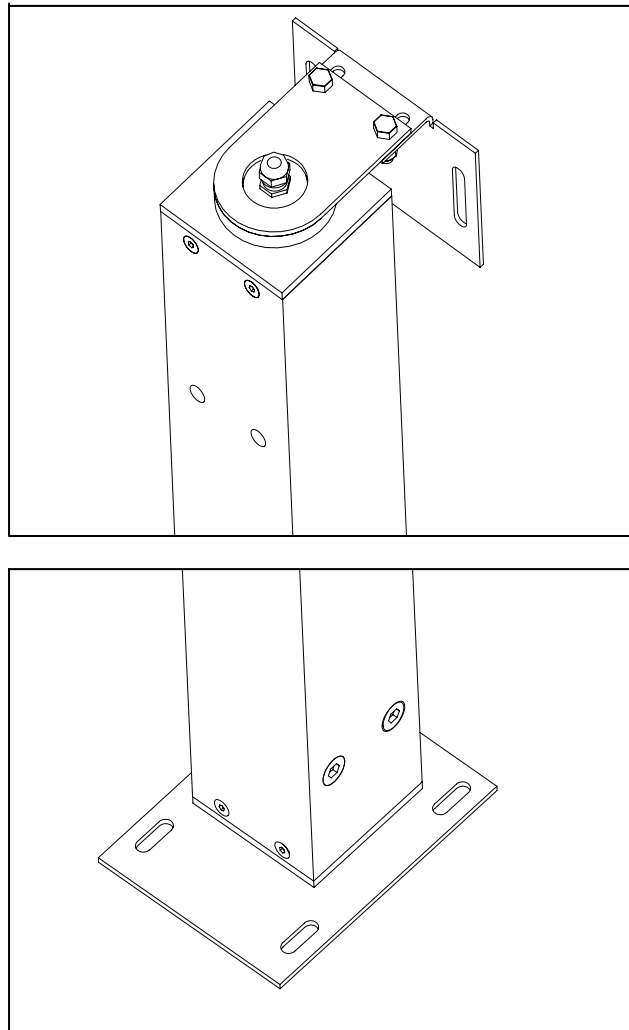

Give your customer what they want – automatic gates – with nothing to see!

The INTEGRA motor is fitted right inside the hinge style of your gate!

Why are underground systems so popular? Because people do not want to see ugly motors on the back of their beautiful gates.

Now the INTEGRA offers the advantages of an underground system without all the problems.

No foundation boxes to set in – everything pre-fabricated in your workshop, No drainage to dig or lids in the ground, motors safely installed out of harms way.

No boxes to rust or fill with water ! **Cuts installation time by up to two thirds**

.General Measurements:

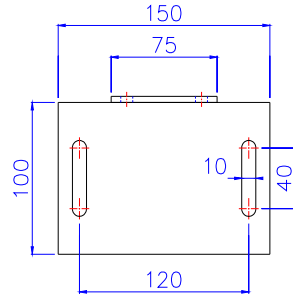
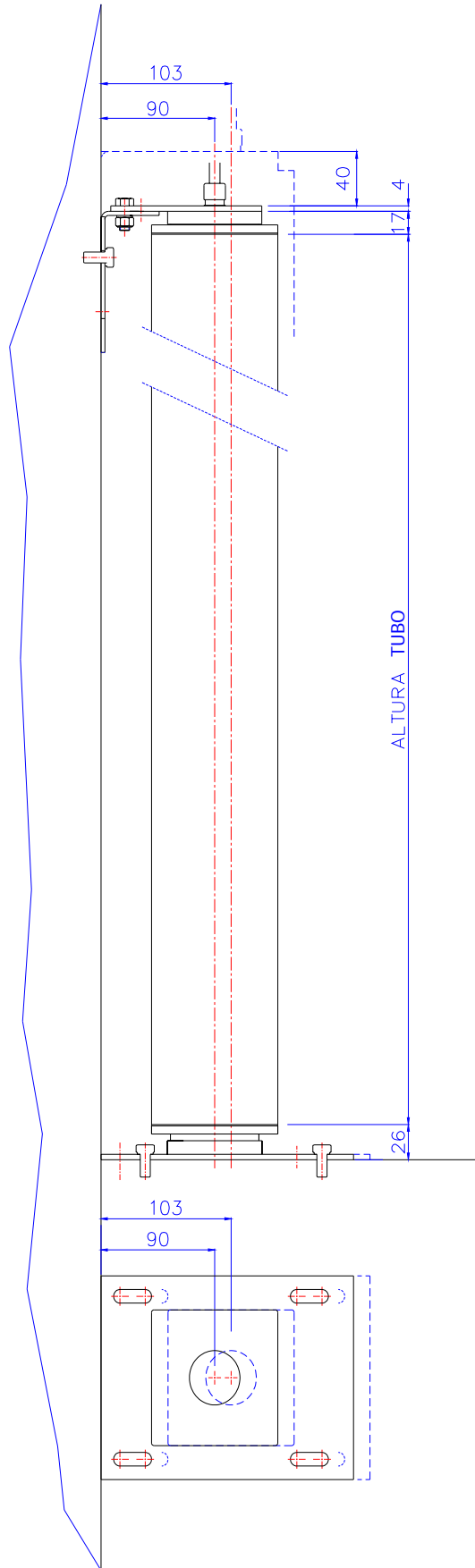

Tube dimensions

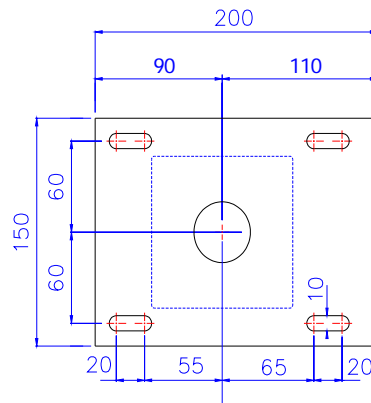
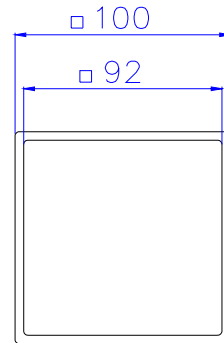

Tube measurements

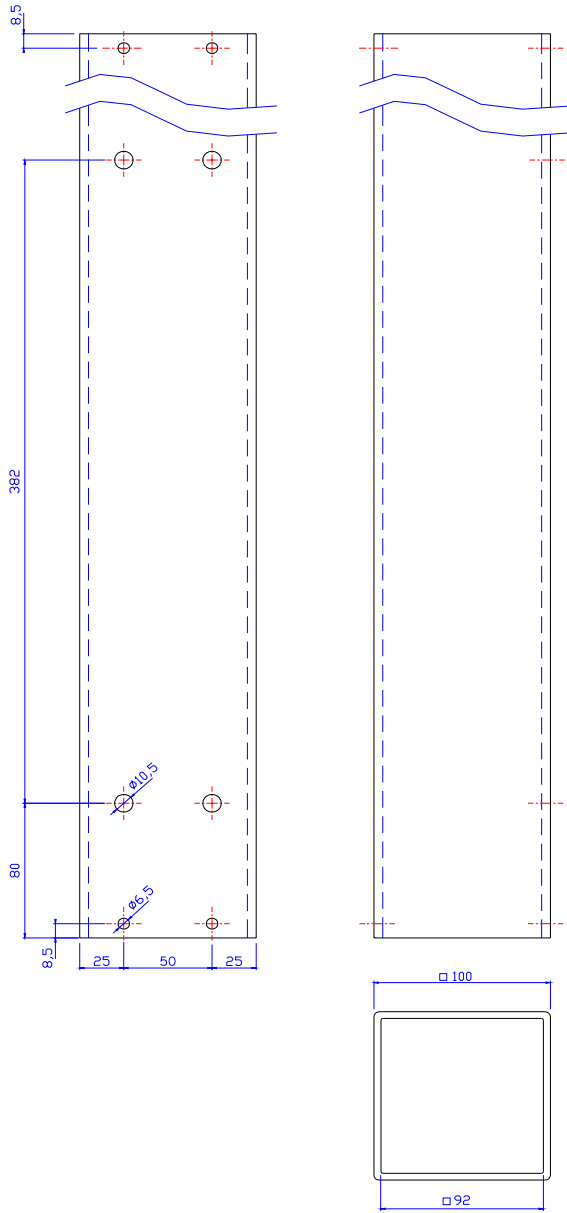

Hole drilling template (Supplied with the kit)

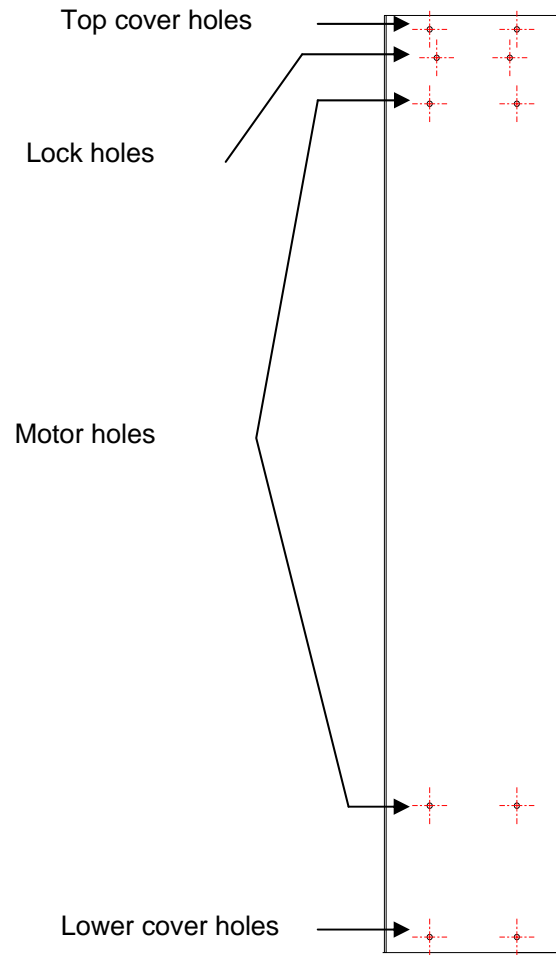

Mounting the Unit

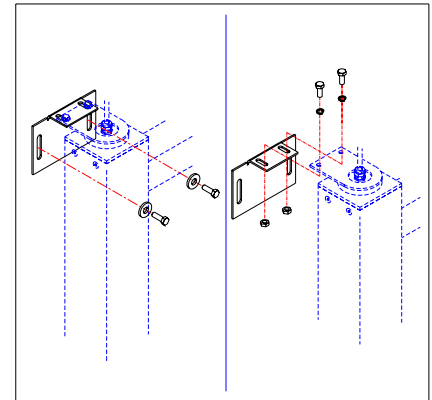
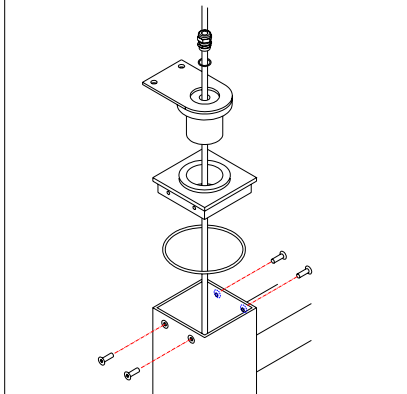
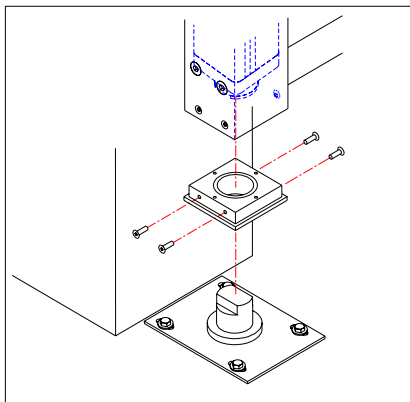
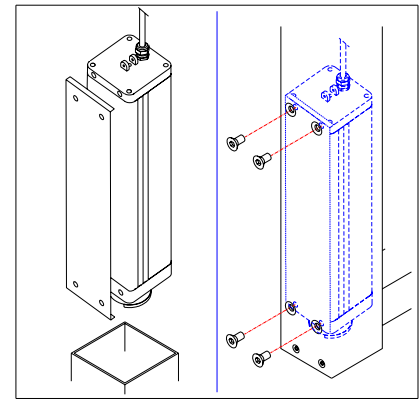
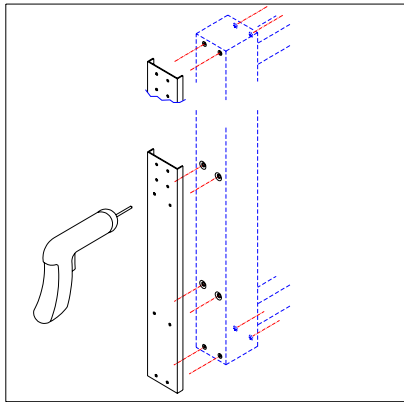
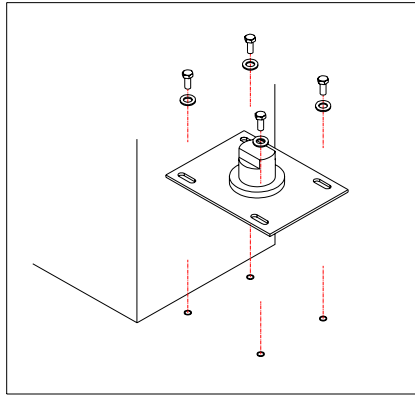

All items shown apart from the drill, tube and the bolts to fix to the ground and post are supplied with the kit

Technical Characteristics:

Model:	T-2010	T-2010F
Power supply:	230V-50Hz	230V-50Hz
Current consumption:	1 A	1 A
Power consumption:	220w	220w
Opening speed:	1.33 rpm	1.33 rpm
Working temperature:	-20° - +60°	-20° - +60°
Use factor:	20 uses per hour	20 uses per hour
Blocking:	NO	Electro brake
Dimensions:	Outer tube 100 x 100	Outer tube 100 x 100
Motor weight:	-	-
Maximum opening angle:	180°	180°
Opening time (90°):	12-20 sec	12-20 sec
Maximum leaf length:	*2500 mm	*1800 mm
Maximum leaf weight:	*500 Kg	*500 Kg
Safety device:	Encoder	Encoder
Soft start and soft stop:	YES	YES
Unlocking:	Electro lock	Cylinder key

Available from:- Linkcare Ltd. 15 Chiltern Business Village, Arundel Road, Uxbridge UB8 2SN

Email:-info@linkcare.net, Tel:- 01895 232626, Fax:- 01895 251001